



**Electrolux**  
PROFESSIONAL

**High Productivity Cooking**  
**Touchline tilting kettle, gas (71652**  
**BTU), 26 gal (100 lt) with 2" TDO valve**

ITEM # \_\_\_\_\_  
MODEL # \_\_\_\_\_  
NAME # \_\_\_\_\_  
SIS # \_\_\_\_\_  
AIA # \_\_\_\_\_



587040 (PBOT10GCWF)

Touchline Tilting Kettle, gas, 26 gallon (100 Lt) capacity, stainless steel construction, full jacket, safety valve, safety thermostat, motor assisted tilt, 2" tangent draw-off valve, 71652 BTU

### Short Form Specification

**Item No.** \_\_\_\_\_

Touchline Tilting Kettle, gas, 26 gallon (100 Lt) capacity, stainless steel construction, full jacket, safety valve, safety thermostat, motor assisted tilt, 2" tangent draw-off valve, 71652 BTU

### Main Features

- Kettle is suitable to boil, steam, poach, braise or simmer all kinds of produce.
- Kettle is jacketed up to 5.27" (134 mm) from upper rim.
- Isolated upper well rim avoids risk of harm for the user.
- Ergonomic vessel dimensions, with a large diameter and shallow depth facilitates stirring and gentle food handling.
- IPX6 water resistant.
- Edge of the large pouring lip can be equipped with a strainer (option).
- Motorized, variable pan tilting with "SOFT STOP". Tilting and pouring speeds can be precisely adjusted. Pan can be tilted over 90° to facilitate pouring and cleaning operations.
- Built in temperature sensor to precisely control the cooking process.
- USB connection to easily update the software, upload/download recipes and download HACCP data.
- [NOT TRANSLATED]

### Construction

- Cooking vessel in 1.4435 (AISI 316L) stainless steel featuring directional pouring lip. Double-jacket in 1.4404 (AISI 316L) stainless steel designed to operate at a pressure of 22 psi (1.5 bar).
- External panelling and internal frame made of 1.4301 (AISI 304) stainless steel.
- Double-lined insulated lid in 1.4301 (AISI 304) stainless steel mounted on the cross beam of the unit, counterbalanced by a hinge that remains open in all positions.
- 2" tangent draw-off valve.
- Safety valve avoids overpressure of the steam in the double jacket.
- Safety thermostat protects against low water level in the double jacket.
- Ergonomic and user friendly thanks to the high tilting position and the pouring lip design which allow to easily fill containers.
- Water mixing tap is available as optional accessory to make water filling and pan cleaning easier.
- Front-mounted inclined led "TOUCH" control panel with recessed deep drawn casing, features self-explanatory display functions which guide operator throughout the cooking process: simultaneous display of actual and set temperature as well as set cooking time and remaining cooking time; real time clock; "SOFT" control for gentle heating up for

APPROVAL: \_\_\_\_\_

delicate food; 9 power simmering levels from gentle to heavy boiling; timer for deferred start; error display for quick trouble-shooting.

- Minimised presence of narrow gaps for easier cleaning of the sides to meet the highest hygiene standards.
- Possibility to store recipes in single or multiphase cooking process, with different temperature settings.
- Can be prearranged for energy optimisation or external surveillance systems (optional).
- 98% recyclable by weight; packaging material free of toxic substances.
- [NOT TRANSLATED]
- [NOT TRANSLATED]

### User Interface & Data Management

- Connectivity ready for real time access to connected appliances from remote and data monitoring (requires optional accessory - contact the Company for more details).

### Included Accessories

- 1 of Food Tap Strainer Rod PNC 910162
- 1 of Food Tap Strainer PNC 911966
- 1 of 2" tangent draw-off valve for braising pans. Factory mounted only, increased lead time PNC 913571

### Optional Accessories

- Strainer for 26 gallon kettles PNC 910003
- Basket, for 26 gallon kettles PNC 910023
- Base plate, 26 gallon (100 liter) for kettles PNC 910033
- Food Tap Strainer Rod PNC 910162
- Left cover plate and mixing faucet for kettle (587040), and all braising pans (587037, 587039, 587031, 587035, 587027, 587028, 587021, and 587025) PNC 911819
- Food Tap Strainer PNC 911966
- Spray gun for tilting units, height 27-1/2" (698.5mm) - factory fitted PNC 912776
- 4 flanged feet, 2", for prothermetic units (kettles, braising pans & pressure braising pans) PNC 913438
- Measuring rod for tilting kettle 26 gallon PNC 913503
- - NOT TRANSLATED - PNC 913577
- Spray gun kit for free-standing ProThermetic Tilting units H=700 - US - Field Mounted PNC 913579

Front

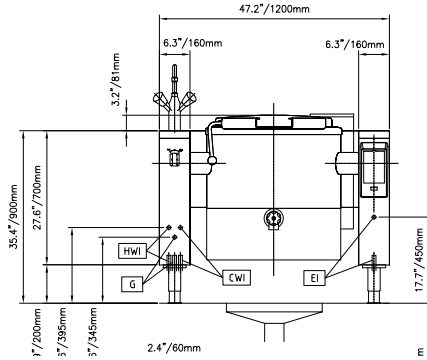

Side

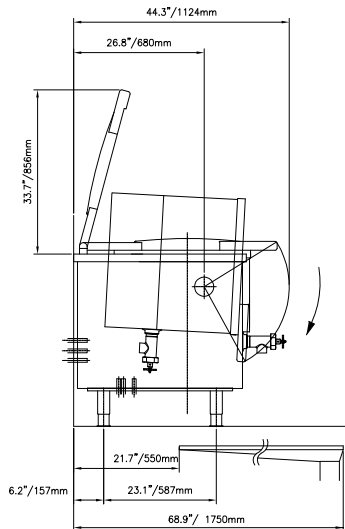

CWII = Cold Water inlet      HWI = Hot water inlet

EI = Electrical connection

G = Gas connection

Top

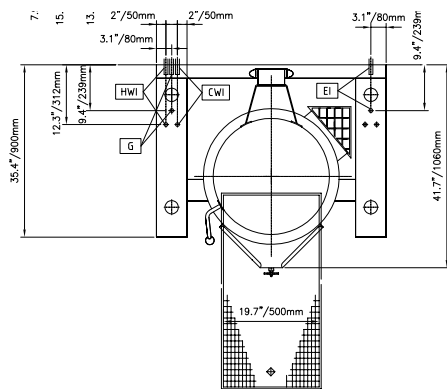

## Electric

Supply voltage: 120 V/1 ph/60 Hz  
 Total Watts: 0.25 kW

## Gas

Gas Power: 71652 Btu/hr (21 kW)  
 Gas Type Option: Propane  
 Gas Inlet: 3/4"

## Water:

Pressure: 29-87 psi (2-6 bar)

## Installation:

Type of installation: FS on concrete base; FS on feet; On base; Standing against wall

## Key Information:

Working Temperature MIN: 122 °F (50 °C)  
 Working Temperature MAX: 230 °F (110 °C)  
 External dimensions, Width: 47 1/4" (1200 mm)  
 External dimensions, Depth: 35 7/16" (900 mm)  
 External dimensions, Height: 27 9/16" (700 mm)  
 Net weight: 507 lbs (230 kg)  
 Shipping width: 51 3/16" (1300 mm)  
 Shipping depth: 53 9/16" (1360 mm)  
 Shipping height: 50 3/8" (1280 mm)  
 Shipping weight: 822 lbs (373 kg)  
 Shipping volume: 79.91 ft<sup>3</sup> (2.26 m<sup>3</sup>)  
 Configuration: Round; Tilting  
 Heating type: Indirect  
 Tilting mechanism: Automatic